

J. B. FABRICATIONS LIMITED BATTERY CHANGING REQUEST

CUSTOMER REF/ORDER No: _____

TRUCK TYPE: _____

THIS ORDER CANNOT BE PROCESSED UNTIL THE FOLLOWING INFORMATION HAS BEEN RECEIVED

Type of Equipment Required (please enter quantity)

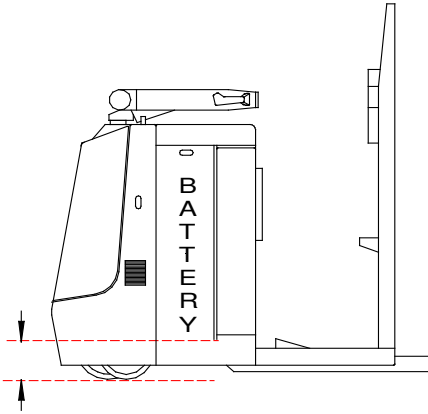

Double Battery Stand: _____

Double Battery/Charger Stand: _____

Triple Battery Stand: _____

Triple Battery/Charger Stand: _____

Double Battery Plinth: _____

Triple Battery Plinth: _____

BATTERY DIMENSIONS

A: _____

B: _____

C: _____

BATTERY TYPE: _____

BATTERY WEIGHT: _____ KG

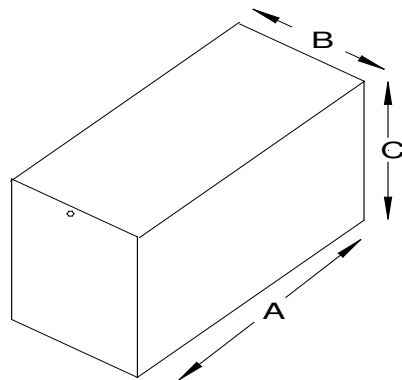

CHARGER DIMENSIONS

A: _____

B: _____

C: _____

CHARGER TYPE: _____

CHARGER WEIGHT: _____ KG

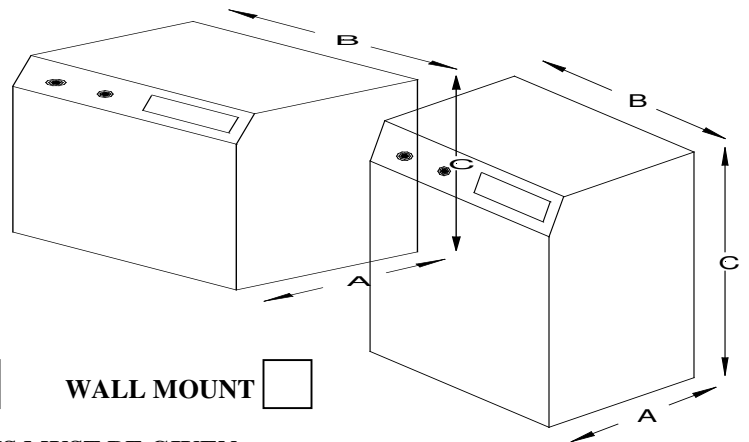

FLOOR MOUNT

WALL MOUNT

HOLE DIMENSIONS MUST BE GIVEN

STANDARD CONFIGURATION IS AS FOLLOWS –

DOUBLE BATTERY STAND = 1 CHARGER

TRIPLE BATTERY STAND = 2 CHARGERS

ANY OTHER CONFIGURATION EG. A BATTERY CHARGER PER BATTERY SPACE YOU NEED TO CONTACT JB FABRICATION

SIGNED:

J. B. FABRICATIONS LIMITED

DATE:

THANK YOU FOR YOUR ENQUIRY